



Mercedes-AMG GT S

Handcrafted by Racers.



Start Up



Accel Exterior



Accel Interior



Pass By





*Please read the disclaimer.



Here it is – the statement from Affalterbach: long bonnet, cockpit positioned far back, wide and powerful rear end. These are the proportions of a sports car from Mercedes-AMG. Its instinct is to rush forward. The Mercedes-AMG GT S.

HANDCRAFTED BY RACERS.

GT



S

*Please read the disclaimer.



8

The outstanding performance is further boosted in the new Mercedes-AMG GT S. With additional highlights that allow configuration of vehicle systems to make it desirous of a race track, the Mercedes-AMG GT S is an outstanding expression of the essence of AMG.





*Please read the disclaimer.

The new Mercedes-AMG GT S embodies the sensual purity of sportiness and emotion. The two-seater is characterized by hallmark rear-wheel-drive proportions. The V8 biturbo front mid-engine ensures optimum weight distribution, which forms the basis for superb driving dynamics. The long bonnet with its pronounced powerdome, the greenhouse which has been moved far back, the large wheels and broad tail end make up the distinctive looks. The large tailgate conceals a practical luggage compartment.

A close-up, low-angle shot of the 'AMG' logo on a racing flag. The letters are large, bold, and yellow, set against a black background with a yellow and black checkered pattern. The perspective is from a low angle, making the letters appear to rise from the surface.

Here to thrill you.

Full of intent, even when stationary. The prominent wheel arches exude power. The pronounced waistline running along the entire side wall merges into muscular shoulders. Its supreme might is concentrated in the dynamic rear end, waiting to pounce.







**WE
DREAMT OF
A TRUE
DRIVING
MACHINE.
IT COULD
ONLY LOOK
LIKE THIS.**



In each of the narrow LED tail lights, 18 white, centrally positioned sequentially flashing prisms of the indicator showcase the aspirations of the Mercedes-AMG GT S. Fascinatingly attractive, with a characteristic night design. By integrating and visually emphasizing the turning direction in the signalling pattern of the tail lights, we have enhanced the lights' visibility and, in turn, improved the car's safety.



The LED High Performance headlamps exude luminous power, safety and efficiency. The LED projection technology in the low beam and the LED reflection technology in the high beam provide for optimum illumination of the road. A distinctive touch: the LED optical fibre above the low beam combines daytime running lamps and indicators.



*Please read the disclaimer.



*Please read the disclaimer.



Fast is not enough. The dual clutch transmission shifts gear more quickly: up to 60% faster in the sporty modes than in C mode.

The Mercedes-AMG DRIVE UNIT: your direct connection to the road. Three pre-set and one individually adjustable transmission mode can be selected via the Mercedes-AMG DYNAMIC SELECT Controller. C, S, S+ and I* - each with its own character. The sportier the mode, the more agile the responsiveness, the shorter the shift times and the more dynamic the tuning. Exclusive to the Mercedes-AMG GT S: RACE transmission mode. High performance to racing standard.

*Please read the disclaimer.



FULL CONTACT

The AMG RIDE CONTROL sports suspension with adaptive damping – a standard feature on the Mercedes-AMG GT S – combines pronounced performance with the ultimate in refined ride comfort. In conjunction with the double wishbone concept it enables race track performance with excellent lateral dynamics and driving stability at high speeds. It adapts the damper characteristics of each individual wheel to the style of driving and the condition of the road.

*Please read the disclaimer.

A close-up, vertical view of a car's front wheel and suspension components, showing the tire, brake disc, and control arms. The image is partially visible on the left side of the page.

THE IDEA

HAS ALWAYS BEEN TO BUILD AN

EIGHT-

CYLINDER

ENGINE LIKE NONE BEFORE IT.

209*

*Dry weight of the AMG 4.0-litre V8 biturbo engine in kg.

Light. Compact. Powerful. The dry weight of the new AMG V8 engine stands at only 209 kg. The aluminium crankcase is sand-cast and produced in closed-deck design. This offers maximum strength combined with low weight. The two turbochargers are installed in the so-called “hot inside V”. This enables an even more compact design, an optimised airflow and perfect inflow conditions for the turbochargers. The overall result is optimum engine response and improved emissions. To ensure the highest possible thermal diffusivity and conductivity, the cylinder head alloy incorporates zircon. And for maximum durability and friction-optimised running, the cylinder walls are lined with the NANOSLIDE® technology developed by Daimler.

Mercedes-AMG GT S

375 kW (510 hp) and maximum torque of 650 Nm.
The AMG 4.0-litre V8 biturbo in the Mercedes-AMG GT S.

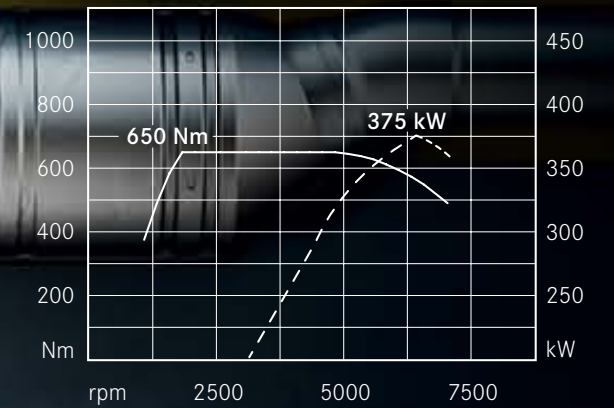

Speed in rpm

— Torque in Nm

- - - Output in kW



Primed for performance.

A sports car's excellent performance is based on optimum distribution of its weight. The aim is to attain the lowest possible centre of gravity. This is achieved with the front mid-engine which is fitted low in the aluminium spaceframe. The engine employs dry sump

lubrication. Lubrication takes place via a suction pump, a pressure pump and an external oil tank. This ensures an ideal supply of oil even at high lateral acceleration. Another aim is perfect balance. To this end, the dual clutch transmission sits on the rear axle.

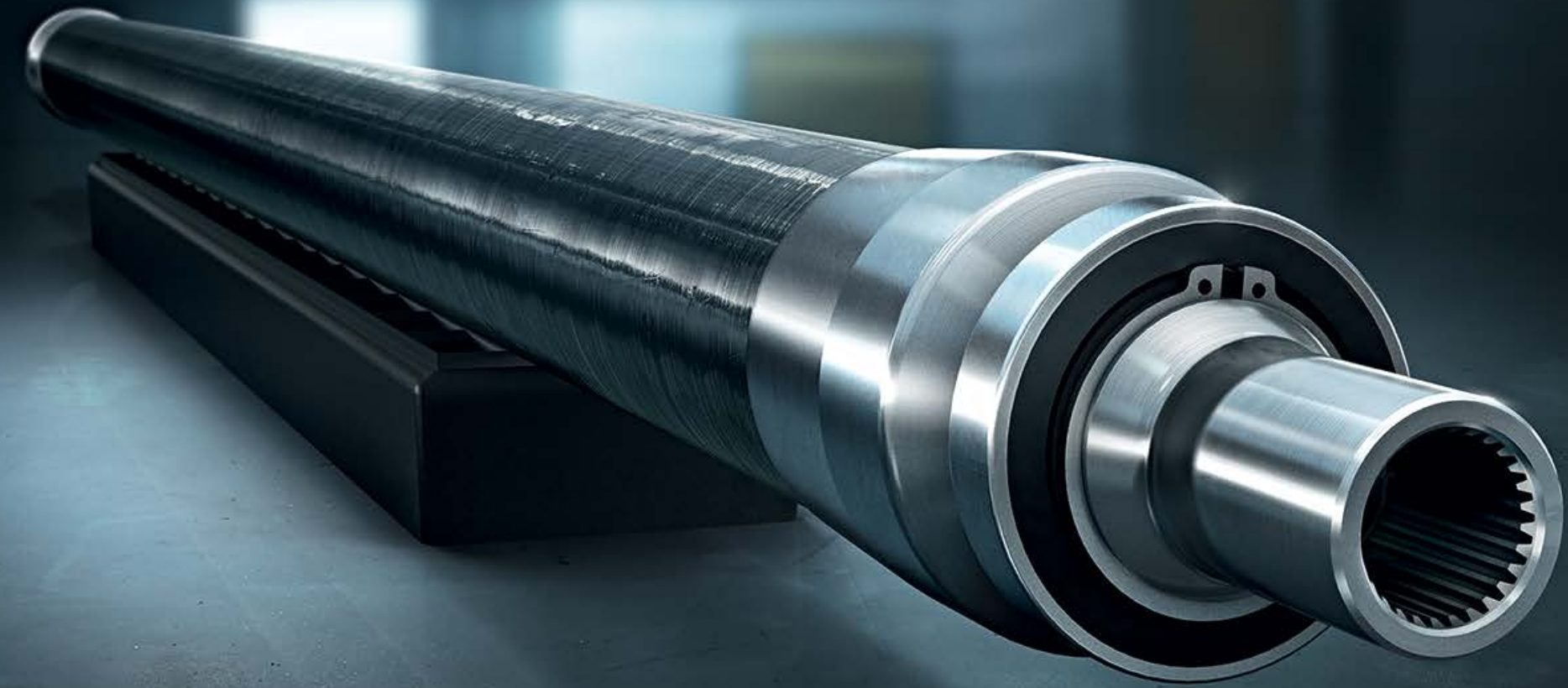

By means of a transaxle configuration we connect the front mid-engine to the dual clutch transmission positioned at the rear to form a fixed unit. The two components are connected via the a torque tube for resistance to bending and torque and support each other. An extremely light and torsion-resistant drive shaft made of carbon rotates inside,

transferring the output of the 4.0-litre V8 biturbo engine to the AMG SPEEDSHIFT DCT 7-speed sports transmission. The transmission duly converts the power into acceleration. In incredibly fast and breath-taking style.



47/53*

That is our formula for success when it comes to sports cars. Taking the balance of the new Mercedes-AMG GT S as a basis, our engineers have relocated the weight a crucial step towards the rear.

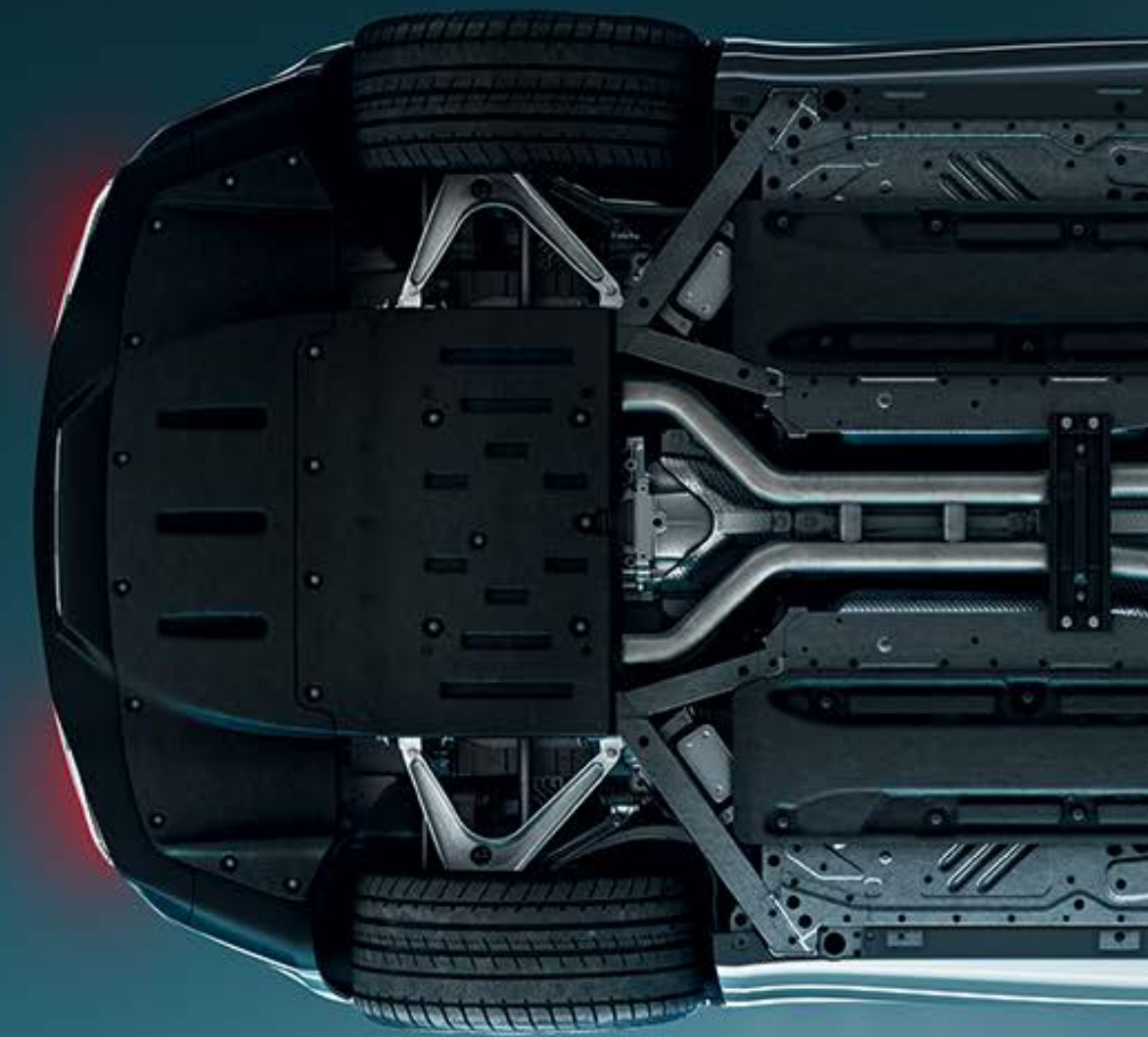

*Lighter at the front than at the rear.

With a weight distribution of 47 to 53 percent between front and rear axle and the vehicle's lower centre of gravity, the new Mercedes-AMG GT S offers unique handling and impressive agility.

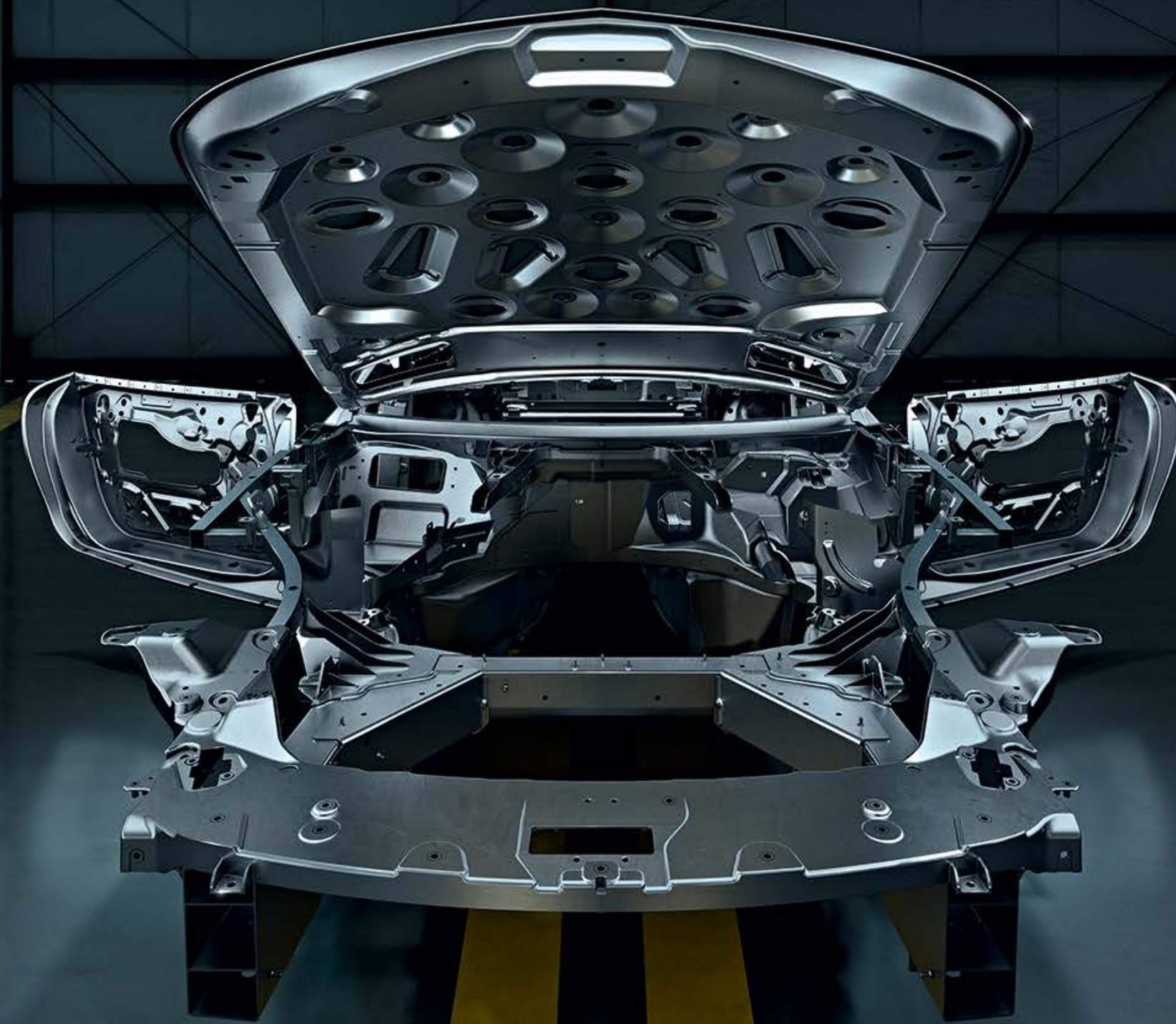

Raceframe.

Aluminium. Magnesium. Steel. These are the ingredients for the body-in-white of the new Mercedes-AMG GT S. The spaceframe consists largely of aluminium and weighs only 231 kg. An innovative architecture which is light, robust and extremely rigid in one. This provides the essential basis for the best possible lateral and longitudinal dynamics and maximum steering precision. The extremely light front module made of magnesium

reduces the mass inertia ahead of the front axle and optimises the sports car's agility. The boot lid is made of high-strength steel. If we had produced it in aluminium, it would have been heavier in order to ensure the necessary rigidity. That's what we understand by intelligent lightweight design.



Brake power.

*Please read the disclaimer.

AMG high-performance composite brake system with red brake callipers, standard for the Mercedes-AMG GT S. Diameter front 390 mm, rear 360 mm, internally ventilated and perforated. Designed for higher performance and enhanced braking force.



AMG ceramic high-performance composite brake system*, diameter front 402 mm, rear 360 mm, internally ventilated and perforated. 40% lighter than conventional composite disc brakes. Maximum service life, excellent deceleration values and precision brake control even under extreme loads.



*Optional item for Mercedes-AMG GT S.

**TRUE CRAFTSMANSHIP
IS FOUNDED ON
EXPERIENCE,
DEDICATION AND
A HEALTHY
DOSE OF
CRAZINESS.**

When we build a sports car, we go the whole mile. And no half measures in the cockpit, either. On the contrary – the design of the interior in the new Mercedes-AMG GT S follows our 'Driving Performance' philosophy.

Every material we opt for and every colour and form we give it imparts the exclusive feeling of driving an AMG.

*Optional item for Mercedes-AMG GT S.

AMG. Up close.

The cockpit. This car has the AMG DNA. The dynamic centre console rises gently up to the dashboard with the four striking air vents. Radically sporty. The rev counter registers every surge into a new power dimension with consummate precision. The AMG Performance seats offer perfect lateral support in every bend. Hands on the AMG Performance steering wheel, speeding the car along via the shift paddles – this is the true feel of the road. Tailor-made for feel-good vibes with extremely high-class workmanship, finest leather and carbon fibre. Hand-crafted character.

Tailor-made.
Down to the finest decibel.

High-performance on the audio front, too. The Burmester® surround sound system has been developed especially for the architecture of the new Mercedes-AMG GT S. The specialists from Burmester® and the engineers from Mercedes-AMG worked closely together to achieve a perfect sound. The special requirements pertaining to integration of the components, the materials and the sports car's acoustic attributes were examined closely. By way of example: specific sealing measures transformed the aluminium spaceframe into a perfect resonance chamber for the 165 mm high-end woofers in the footwells. The fully active Burmester® surround sound system comprises 10 high performance loudspeakers and a high-end amplifier with an output of 640 W – for a unique audio experience and an impressive depth of sound.





(S)PACEMAKER



Standard Equipment



Panoramic sunroof



Electronic AMG rear axle differential locks



Burmester® surround sound system with 10 high performance speakers



High Performance headlamps. Innovative LED technology for optimum illumination and reduced energy consumption



Instant joy at the push of a button. Just press the button for the KEYLESS-GO starting function to experience high performance



AMG high-performance composite brake system with red brake callipers.

Standard Equipment

designo

designo appointments allow customers seeking a unique identity for their vehicles to select their appointments in accordance with their own particular ideas and preferences. All design requests are implemented using carefully chosen materials which are painstakingly crafted by hand using traditional skills. The interior indulges the senses with high quality, hand-stitched dual tone *designo* leather upholstery with topstitching that matches the exterior paint finish. The appointments also comprise of door panels in leather, velour floor mats with *designo* leather surround and headlining in black DINAMICA microfibre.

Upholstery



Two tone exclusive nappa leather white / black



Two tone exclusive nappa leather silver pearl / black



Two tone exclusive nappa leather red pepper / black

Seat Belts



designo Red seat belts



Seat belts in Silver



Seat belts in Black

Trims



AMG carbon-fibre trim



AMG matt carbon-fibre trim



AMG matt silver glass-fibre trim



AMG Interior Silver Chrome package

Optional Packages



AMG Exterior Carbon-Fibre package.

The stuff that racing dreams are made of: carbon fibre. The front splitter, the fins in the wing, the exterior mirror housings and the one-piece diffuser in the rear bumper are all made of carbon fibre. The louvre in the diamond grille comes in high-gloss black. Pure dynamism that emphasizes the forward thrust of the new Mercedes-AMG GT S.



Optional Packages

Carbon Fibre Package

AMG carbon fibre door sill panels in high gloss: AMG carbon fibre door sill panels in high gloss give a racing-car feel as soon as the doors are opened. They also protect the entrance area from damage.



AMG carbon fibre door sill panels in high gloss
(* Available at an additional cost)

AMG Carbon Fibre Engine Cover: High-quality genuine carbon fibre underscores the engine's power in an imposing manner. The cover emphasizes both the vehicle's sportiness and the structured arrangement of the engine components.



AMG carbon fibre engine cover

Ceramic High-Performance Braking System

Extremely short stopping distances, precise pressure point and outstanding fade resistance even in extreme operating conditions - the AMG ceramic high performance composite brake system offers race-track braking performance accompanied by weight savings of around 40% over conventional compound brake discs.



AMG high performance ceramic composite braking system

High-end Surround Sound System

Burmester® high-end 3D surround sound system comes with 11 specially designed High-End speakers, 11-channel amplifier with a total system output of 1000 watts, as well as technologies developed specifically for the vehicle, ensure an extraordinarily expressive and intriguing 3D sound - the Burmester® "feel-good sound".



Burmester® high-end surround sound system

Optional Packages

AMG Performance Seats

More pronounced contouring of front seats for enhanced lateral support, integral head restraints and AMG badge in seat backrests. The contouring of the side bolsters for the seat cushion and backrest of the AMG performance seats offers superior lateral support, while the seat design gives the interior a sporty and distinctive look.



Nappa leather / DINAMICA Exclusive microfibre
black with yellow stitching with heated seats



Nappa leather / DINAMICA Exclusive microfibre
black with grey stitching with heated seats



Nappa leather / DINAMICA Exclusive microfibre
black with red stitching with heated seats



765

658

663

659

Pit stop.

Whichever set you go for, the AMG light-alloy wheels and the AMG forged wheels offer grip, agility and driving dynamics. Lightweights that make their mark on the road.

765 | 5-spoke AMG light-alloy wheels, painted in titanium grey with a high-sheen finish, with 265/35 R 19 front and 295/30 R 20 rear tyres.

663 | 5-spoke AMG light-alloy wheels, painted in matt black grey and with a highsheen rim flange, with 265/35 R 19 front and 295/30 R 20 rear tyres.

658 | AMG cross-spoke forged wheels, painted in titanium grey and polished, including fully integrated wheel bolt cover, with 265/35 R 19 front and 295/30 R 20 rear tyres.

659 | AMG cross-spoke forged wheels, painted in matt black with high-sheen rim flange, including fully integrated wheel bolt cover, with 265/35 R 19 front and 295/30 R 20 rear tyres.

Metallic Paints

Special Paints

Upholstery

Trim

183 magnetite black

775 iridium silver

896 brilliant blue

992 selenite grey

278 AMG solarbeam*

996 designo hyacinth red metallic

555 Exclusive nappa leather in white/black

557 Exclusive nappa leather in red pepper/black

558 Exclusive nappa leather in silver pearl/black

H70 AMG Interior Silver Chrome package

H73 AMG carbon fibre

H84 AMG matt silver glass - fibre trim

H77 AMG carbon fibre matt

*Additional cost applicable



Enough said.

	Mercedes-AMG GT S
Arrangement/No. of Cylinders	V8
Total displacement (cc)	3982
Rated output (kW (hp) @ rpm)	375 (510) @ 6250
Rated torque (Nm @ rpm)	650 @ 1750 - 4750
Acceleration (0-100 kmph, s)	3.8
Top speed (km/h)	310
Tyres/wheels size, front	265/35 ZR19
Tyres/wheels size, rear	295/30 ZR20
Fuel	Petrol
Tank Capacity (l)	75
Boot Capacity (l)	285 to 350
Turning Circle diameter (m)	11.5
Kerb weight (kg)	1645
Permissible gross vehicle weight (kg)	1890
L x W x H (mm)	4546 x 1939 x 1288
Wheelbase (mm)	2630

*Please read the disclaimer.



Time to drive it.

Climb aboard and experience the new Mercedes-AMG GT S on a test drive. Your Mercedes-Benz dealer will be happy to advise you.

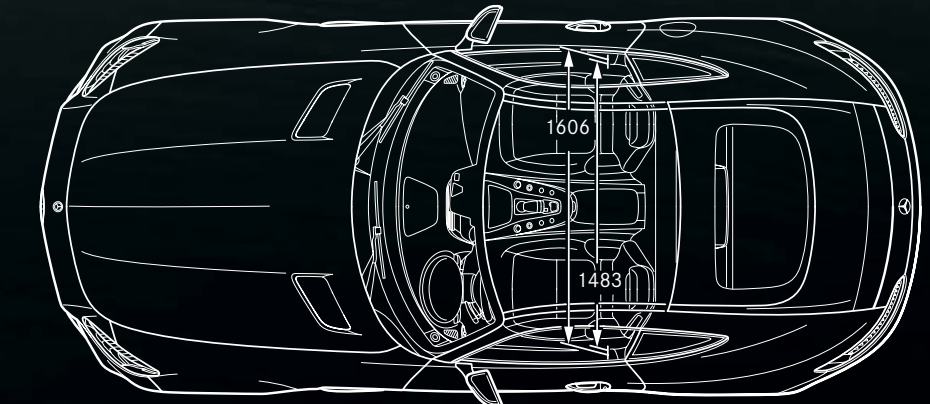
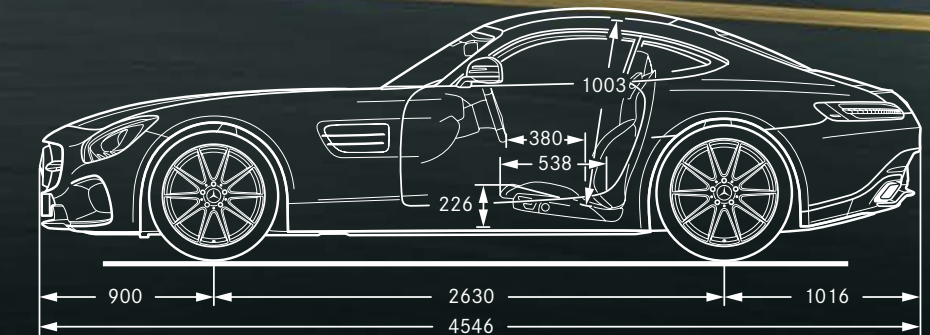
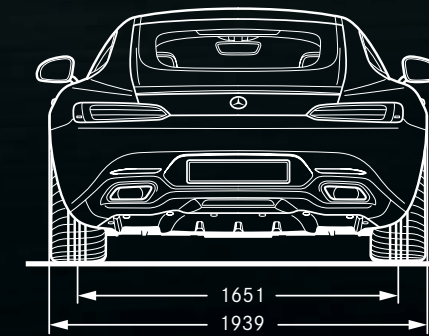
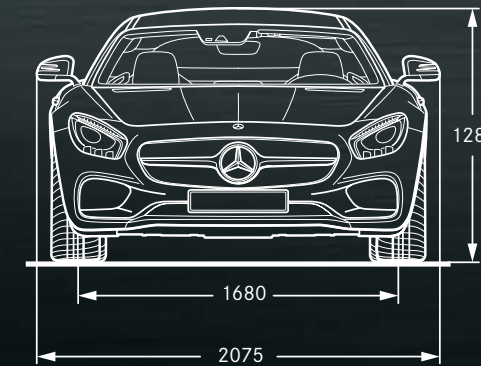

*Please read the disclaimer.

India's Largest Luxury Car Network

It takes a keen sense of responsibility to provide the Best. Our large network is spread across the country in 40 cities with 81 outlets and is still growing. With world-class showrooms, state-of-the-art workshops and highly skilled personnel, experience the best wherever you go.



DEALER CONTACT:

NORTH & EAST:

BHUBANESWAR:
Tristar Motors: 0-7852944100

CHANDIGARH:
Joshi Autozone: 0172-5050500
Panjab Motors: 0172-4290000

DEHRADUN:
Berkeley Motors: 0135-3054000

DELHI:
Patel Auto Services, Rajendra Place:
011-47626262/0-9810081048

T & T Motors, Mohan Co-operative,
Mathura Road: 011-66574300/330
Rajouri Garden: 011-66574400/430

GHAZIABAD:
Silver Arrows: 0-9718200500

GURGAON:
T & T Motors: 0124-4263060/62

JAIPUR:
T & T Motors: 0141-4300000/05

JAMSHEDPUR:
Tristar Motors: 0-7763815720/
0657-6601601/02

JALANDHAR:
Joshi Autozone: 0181-5004444

KANPUR:
Smart Hoops: 0-8795663300

KARNAL:
Berkeley Motors: 0184-3300000

KOLKATA:
Benchmark Interkrafts: 1800 3000 3310

LUCKNOW:
Smart Hoops: 0522-6004008/9

LUDHIANA:
Joshi Autozone: 0161-5055000

MOHALI:
Panjab Motors: 0172-4290000

NOIDA:
Silver Arrows: 0-9999200500

WEST:

AHMEDABAD:
Benchmark Cars: 0-9377662000

AURANGABAD:
B. U. Bhandari: 0-8605121333/
0240-6452601/02

BHOPAL:
Benchmark Cars: 0-9098233233

GOA:
Counto Motors: 0832-2415122

INDORE:
Benchmark Cars: 1800-3000-8844

KOLHAPUR:
B. U. Bhandari: 0231-2661422/
0-8380093555

MUMBAI:
Auto Hangar, Prabhadevi: 022-67434362/63
Auto Hangar, Andheri: 022-67106660/61

Metro Motors, Auto Hangar division
Hughes Road: 022-66123500/11
Shaman Wheels, Off BKC: 022-24228787

NAVI MUMBAI:
Shaman Wheels: 022-24228787

NAGPUR:
Auto Hangar: 0-9223540191/
07104-238180/1/2/3

NASHIK:
Indisch Motoren: 0253-6645555

PUNE:
B. U. Bhandari, Baner: 020-67212129
Pune City Showroom: 020-67212131

RAJKOT:
Benchmark Cars: 0-9377750050

RAIPUR:
Auto Hangar: 0771-6537801/0-8518887155

SURAT:
Benchmark Cars: 0-9377660066

VADODARA:
Benchmark Cars: 0-9377390001

SOUTH:

BANGALORE:
Sundaram Motors: 080-22070720/21
Akshaya Motors, Mysore Road:
080-22966300, 0-9066030989

Akshaya Motors, Koramangala:
080-22966296, 0-9019326026

CALICUT:
Bridgeway Motors: 0495-30 55555

CHENNAI:
Trans Car: 044-40200300
Titanium Motors: 044-66498080/8181/8282

COIMBATORE:
Sundaram Motors: 0422-2452020

COCHIN:
Rajasree Motors:
0484-2706332/2706432/2706134
2607027/37/47

HYDERABAD:
Mahavir Motors: 040-43403004

MADURAI:
Sundaram Motors: 0452-2320433/
0-9500966946

MANGALORE:
Sundaram Motors: 0824-2214833/2215833/
0-9008442155

TRIVANDRUM:
Rajasree Motors: 0471-2380377/
0-9846547551

VIJAYAWADA:
Mahavir Motors: 0866-2082559/
0-9885303004

MERCEDES-BENZ CERTIFIED:

AHMEDABAD:
Benchmark Cars: 0-9016665000

BANGALORE:
Akshaya Motors: 0-9019944044
Sundaram Motors: 080-22070746/
0-9880662051

CHANDIGARH:
Joshi Autozone: 0-9878941930/ 0172-
5050500/510

CHENNAI:
Transcar: 0-9841049994

DELHI:
T&T Motors, Mathura Road: 0-9711774424
T&T Motors, West Delhi: 0-9711112243

GHAZIABAD:
Silver Arrows: 0-9718200500

HYDERABAD:
Adishwar: 0-7799633004

KOCHI:
Rajasree Motors: 0-9846547311

MOHALI:
Panjab Motors: 0172-4290000

MUMBAI:
Autohangar India: 0-9223546204,
0-9223547099

Shaman Wheels: 0-9619023450/ 022-
69543333

PUNE:
B U Bhandari: 020-67212172/0-8605118555

AMG PERFORMANCE CENTERS:

BENGALURU:
Sundaram Motors: 080-22070720/21

DELHI:
T&T Motors: 011-66574309

HYDERABAD:
Mahavir Motors: 0-9885033004/
0-9885653004

MUMBAI:
Auto Hangar: 022-67434360/61/65

PUNE:
B.U. Bhandari: 020-67212131/0-8554055555

Our national toll-free no.:

1800 102 9222

One Call. All Answers.

For a complete list of
Mercedes-Benz outlets,
please explore the dealer locator
tab on www.mercedes-benz.co.in

Mercedes-Benz India Private Limited: E-3, MIDC Chakan - Phase III, Chakan Industrial Area, Kuruli & Nighoje, Tal: Khed, Pune - 410 501 (India)
Toll free No.: 1800 102 9222. e-mail: customerconnect@daimler.com, **website: www.mercedes-benz.co.in**

Please note: This brochure is intended for general information, description and illustration of the Product including optional functions and equipment and may not be specific to a Product since specification of a product may change from time to time. Optional features, functions and equipment etc. may not be present in the Standard or Variant Product or Special Edition Product. Further, Standard specifications of a product may also vary from time to time. Colours may differ from those shown in pictures in the brochure, owing to printing. Mercedes-Benz India reserves the right to make changes, at any point of time, without prior notice, in design, colours, materials, components, equipment, specifications, features, functions, make and models etc. The information given in this brochure shall be regarded as accurate at the time of going to print and may vary thereafter due to any developments or any other reason. Interested parties should confirm with the Authorised Dealer about the correct specification of the product they desire to purchase. For the latest authentic information and updates, kindly contact your nearest Authorised Dealer.

All title, ownership rights and intellectual property rights in and relating to this brochure / magazine or publication material or any copies thereof including but not limited to copyright, logos, names, trademarks, service marks, design, text, images, links, concepts and themes are owned by Daimler AG and/or its subsidiaries collectively or used under authorised license by the Daimler AG. Any reproduction, transmission, publication, performance, broadcast, alteration, license, creation of derivative works or other use in whole or in part in any manner without the prior written consent of the Daimler AG is strictly prohibited.

Month of going to press: November, 2015. Mercedes-Benz cars: The Mercedes-AMG GT S meets Bharat Stage IV equivalent emission norms.

CIN - U34102PN1994PTC083160